

LORD Active Vibration Control Systems

For Helicopters

LORD Active Vibration Control Systems (AVCS) reduce vibration in the helicopter fuselage generated by the main rotor. Our AVCS provides state-of-the-art, patented algorithms that control steady state and transient vibration, even during start up. As a vibration solution provider, we offer both turn-key AVCS as well as AVCS components, adapting our product offerings to suit your specific vibration control needs.

Features & Benefits

Reduce Weight – Eliminates heavy passive vibration absorbers.

Improve Comfort – Reduces occupant vibration levels in both the cockpit and cabin.

Improve Performance – Enables expanded flight envelope within aircraft design limits and extended range.

Reduce Direct Maintenance Cost – Lowers aircraft vibration levels resulting in less vibration induced fatigue of structures and equipment.

How LORD AVCS Operates

Accelerometers measure aircraft vibration levels and signals are sent to a centralized computer. The computer is running a software algorithm that interprets the signals and sends commands to force generators located throughout the aircraft. These force generators create “anti-vibration” that stops the progression of vibration due to the main rotor.

Multiple Technologies to Fit All Applications

Force generators configured to create linear or circular control forces are available to meet the needs of diverse system requirements.



AVCS components with linear force generators for light helicopters

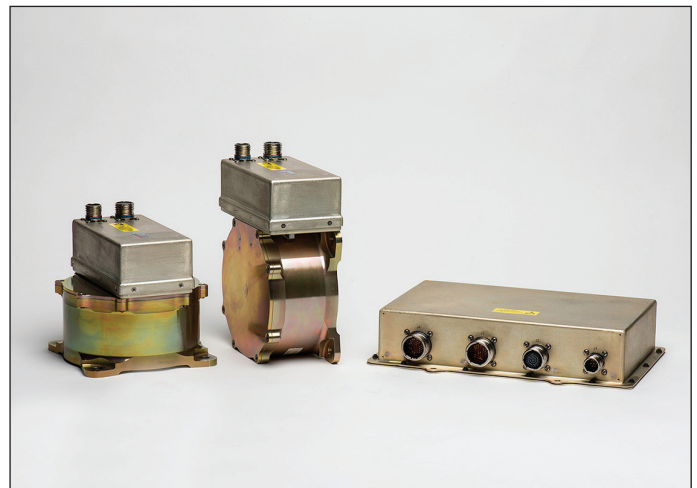

AVCS components with circular force generators for medium and heavy helicopters

Typical Performance

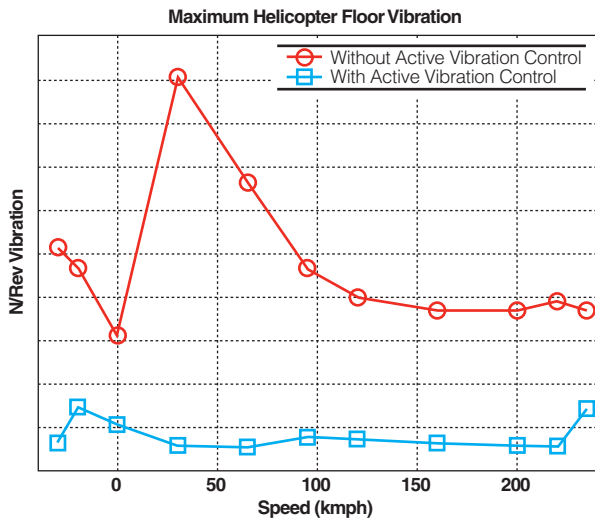

The LORD AVCS can provide significant reduction in helicopter cockpit and cabin vibration over a broad range of operating conditions.

Schematic of Typical LORD AVCS

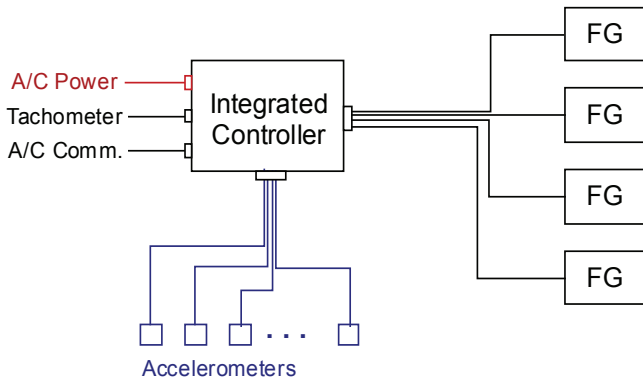

The LORD AVCS features an integrated controller that includes both processing and power electronics. The controller receives a tachometer signal that is synchronized with the main rotor speed and up to 16 accelerometers and drives up to four force generators such that the accelerometer inputs are minimized.

"Ask Us How" is a trademark of LORD Corporation or one of its subsidiaries.

LORD provides valuable expertise in adhesives and coatings, vibration and motion control, and magnetically responsive technologies. Our people work in collaboration with our customers to help them increase the value of their products. Innovative and responsive in an ever-changing marketplace, we are focused on providing solutions for our customers worldwide ... Ask Us How.

LORD Corporation World Headquarters

111 Lord Drive
Cary, NC 27511-7923
USA

Customer Support Center (in United States & Canada)

+1 877 ASK LORD (275 5673)

www.lord.com

For a listing of our worldwide locations, visit LORD.com.

Qualified, Responsive Systems

The power consumption of the LORD AVCS is extremely low. Additionally, many of our AVCS' force generators provide a benign failure mode. The linear force generators tuned to near aircraft N/Rev frequency will act as tuned vibration absorbers (TVAs) and provide passive vibration control should the system lose power.

Our AVCS:

- Are qualified to DO-160D/E and MIL-STD-810 Environmental Standards;
- Are able to accept 115 VAC (400 Cycle) or 28 VDC Aircraft Power;
- Meet MIL-STD-704 and DO-160 for Power Input Requirements;
- Meet MIL-STD-461 and DO-160D/E EMI Requirements;
- Feature software developed to DO-178B standards; and
- Feature electronic hardware designed to DO-254 or internal process standards.